

PANEL FOR CONTROL AND PROTECTION OF IRRIGATION MOTOR PUMPSET

TYPE CEM-390

Complete with electronic transmitter (electronic pressure switch) and digital pressure gauge for pump water pressure.

Enables manual adjustment of the engine rpm and stopping with automatic deceleration.

INSTRUCTION AND USER MANUAL



It is equipped with display to the following functions:

- pump protection exclusion
- battery and oil lights
- protections intervention
- hour-meter
- timer
- partial hour meter
- timer
- pump water pressure gauge
- fuel level indicator
- tachometer
- battery voltmeter

PROTECTS THE MOTOR PUMP GROUP SET BY THEM IN THE EVENT OF:

- low oil pressure
- over-temperature
- belt breakage
- minimum fuel level
- A1 fault available
- A2 (low diesel pressure)
- low coolant level
- insufficient pump water pressure
- pump water overpressure

Assembly on the machine and in the open air.

DIMENSIONS

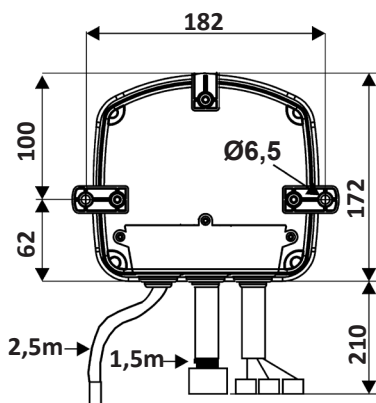

Fixing system

With two or three clamps

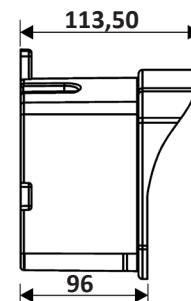

PARMA



ELCOS®

ITALY

Tel. +39 0521/772021 Fax +39 0521/270218
E-mail: info@elcos.it - HTTP://www.elcos.it

BRIEF INSTRUCTIONS

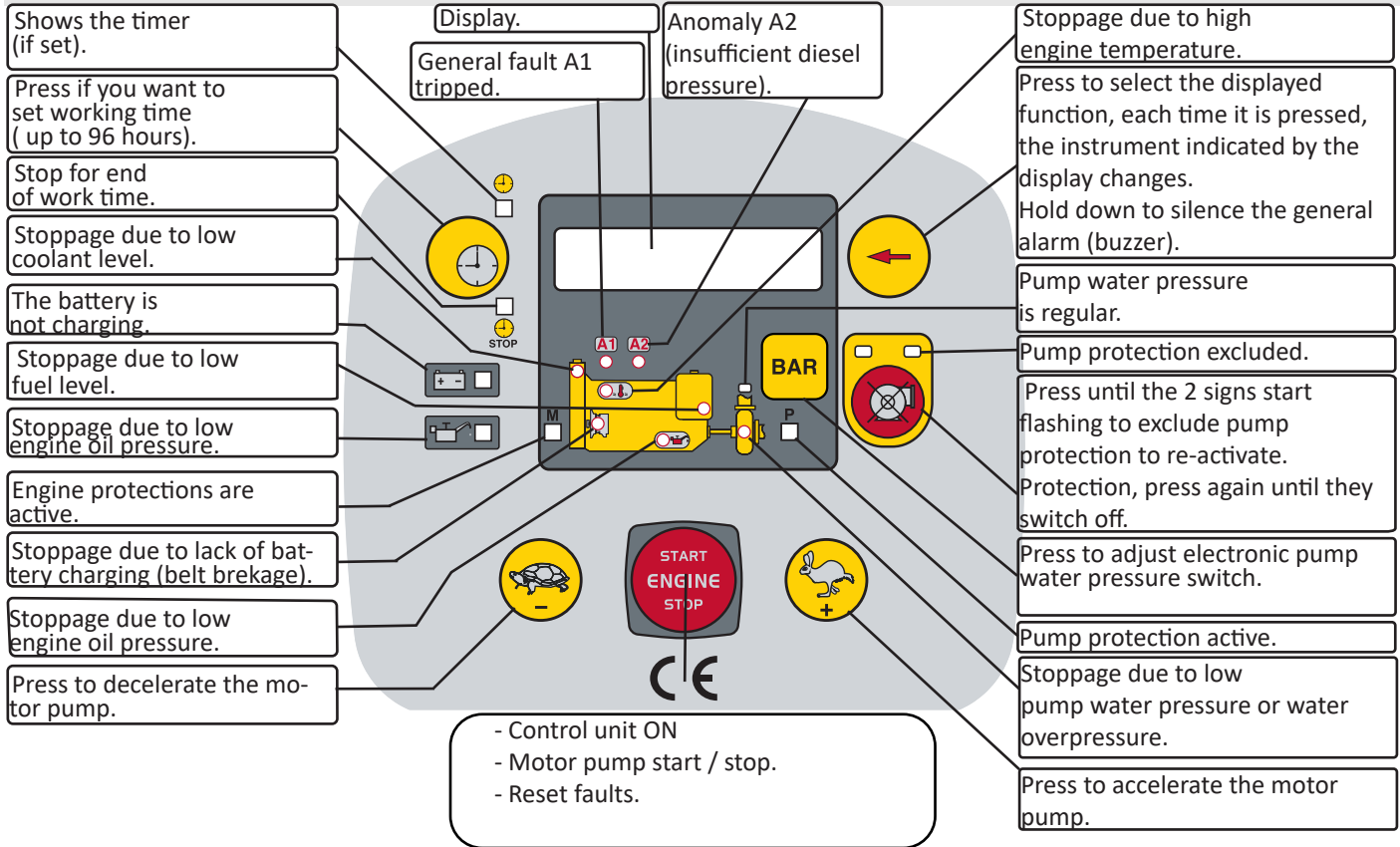

TECHNICAL DATA

Battery voltage supply	12 Vdc 24 Vdc
Voltage supply	8 ÷ 32V
Self-consumption with control unit off	2 mA
Tachometer	Max 4000 RPM precision ± 10 RPM
Timer	1 ÷ 96h
Instrument accuracy: battery voltmeter, fuel level gauge, motor thermometer, oil pressure gauge, pump water pressure gauge	2%
Hour-meter	5 digits
Max load of the outputs: <ul style="list-style-type: none"> starting motor (black) stopping (yellow) preheating (white/brown) auxiliaries (brown) general alarm (red/green) 	40A 3A 3A 3A 3A
Pump water pressure gauge	0 ÷ 21 bar
Pump water pressure transmitter: <ul style="list-style-type: none"> Maximum permissible pressure With pressure 4 ÷ 14 bar With pressure 1 ÷ 4 bar 	21 bar differential 2 bar differential 1 bar
Degree of protection: <ul style="list-style-type: none"> Box front rear Connector 	IP54 IP23 IP20
Installation conditions	for external use
Temperature gauge	-20 ÷ +60°C
Weight	1000 g

OPERATION

MOTOR PUMP START / STOP BUTTON



Motor pump start / stop button.

Used to:

- **Switch on the control unit.** If the control unit is switched off, press the button for at least one second and the control unit will switch on, performing an LED test and checking for any faults.
- **Start the motor pump.** After turning on the control unit, press the button for at least one second. If there are no faults which stop it, the motor pump will start at idling speed. If, on the other hand, there are faults which result in stoppage, the start-up will not occur.
- **Stop the motor pump.** If the motor pump is running, press the button for at least one second. The control unit will activate the rpm variator, reducing the RPM until the engine no longer decelerates for 5 seconds, then the engine stops.
- **Reset faults.** With the engine stopped, press the button to reset any faults.

ACCELERATION - DECELERATION



Motor pump accelerate / decelerate buttons.

Used to manually accelerate or decelerate the engine rpm. When the control unit is on, the buttons are always enabled, even when the engine is stopped. The control unit does NOT automatically adjust the engine rpm.

SETTING ELECTRONIC PRESSURE SWITCH ADJUSTMENT (TRANSMITTER) WATER PUMP

PUMP PROTECTION

NO ADJUSTING IS REQUIRED.

The pump protection is enabled when warning lights PUMP PROTECTION ACTIVE  come on after the water pressure has remained stable for 2 consecutive minutes, in any case 10 minutes after the engine started. Intervention of the protection (5 seconds after the pressure goes up or down by two bars) stops the engine and is shown on the display:

However it is possible to change the two bars of pressure

lowering (subpressure), by pressing button .

This change is deleted, when the engine is stopped.

OVERPRESSURE remains set to two bars, this value is added to the working pressure (for example, working pressure 9 bars overpressure 11 bars)

Press to set the SUBPRESSURE value



WORK. PRESS. 10
SUBPRESSURE. 08

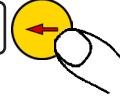

Press to select the WORKING PRESSURE

OVERPRESSURE
Pump water

or

INSUFFICIENT WATER
PRESSURE

Insufficient water
pump pressure
(subpressure)

PUMP PROTECTION EXCLUSION (ENABLED ONLY WITH ENGINE RUNNING)

The push-button  excludes pump protection: exclusion is obtained by keeping it pressed for at least 3 consecutive seconds; the function is indicated by the two intermittent lights,

- This exclusion is cancelled by pressing the push-button,  or by stopping the motor pump.

TIMER

Enabled with key on "AUT", it makes it possible, if necessary, to have the motor pump work for an adjustable length of time (maximum 96 hours), at the end of which it stops and the WORK TIME OVER  sign lights up on the display.

The work time is set by pressing the push-button  (lights up)  until the desired value appears on the DISPLAY.

On releasing the push-button, the timer automatically starts working, continuously displaying the remaining work time.

To zeroing the set time there are two methods: -keep the push-button:



- keep the button  pressed until it reaches zero.

- Stop the motor pump.



ENGINE PROTECTIONS

The engine protections are enabled when the ENGINE PROTECTIONS ACTIVE light  comes on, (20 seconds after the end of starting impulse and however 1 minute after the control unit has been switched on). Interventions of the protection probes (fitted on the engine), indicated by the relevant lights, and the “!” symbol is flashing on the display, stop the engine, they are memorised and can be split into two groups:

Immediate for:

- OIL PRESSURE SWITCH 
- OVERHEATING THERMOSTATIC SWITCH 

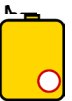
Delayed by 5 seconds for:

- A1 ANOMALY PRESENT
- A2 (LOW FUEL PRESSURE)
- BATTERY CHARGING ALTERNATOR (BELT BREAKAGE)
- FUEL LEVEL SWITCH 
- flashing signal: 20% fuel reserve (T) (WITHOUT ENGINE STOP)
- Signal always on: stop for minimum fuel level (W)
- PROBE FOR COOLANT LEVEL 

CONTROLLING THE CONNECTION OF THE PUMP WATER ELECTRONIC PRESSURE GAUGE (TRANSMITTER)

The cutting of the electronic pressure switch is indicated when the control unit is switched on. The fault is triggered 1 minute after the end of the start-up impulse.

Intervention is highlighted by the relevant indicators  and stops the motor pump after 2 seconds.

To exclude intervention, press the push-button  PUMP PROTECTION EXCLUSION.

PUMP PROTECTION

The pump protection is enabled with the switching on of the ACTIVE PUMP PROTECTION (after 2 consecutive minutes of stable water pressure, indicated by the visual signal REGULAR PUMP PRESSURE  and in any case, 10 minutes after the start of the motor pump).

The intervention of the protection (5 seconds after the increase or decrease of the pressure) stops the engine and is indicated by the visual signal for  LOW PUMP WATERPRESSURE or WATERPUMPOVERPRESSURE .

STOPPAGE OF MOTOR PUMP WITH AUTOMATIC DECELERATION

The control unit automatically decelerates and the engine stops for three reasons:

- by pressing the STOP button.
- protection intervention.
- timer intervention at the end of the work period.

The engine stops when it no longer decelerates for 5 consecutive seconds.

The unit adapts to two different stop system:

- by cutting off power to the SOLENOIDVALVE shutting off the flow of fuel (Factory setting).
- by working the ELECTROMAGNET for 20 seconds which pulls the STOP lever.

EMERGENCY STOP

The emergency stop can be activated in all working conditions, by mounting one or more click-down push-button. On the display it's reported  .

GLOW PLUGS PREHEATING FACTORY-EXCLUDED

Activated by pressing the START button. On the display it's reported EMERGENCY STOP.
Il tempo di preriscaldamento è regolabile.
Once the preheating stops, the engine starts.

GENERAL ALARM

This can be obtained by fitting on the outside an optical and/or acoustic signaller to be connected to the RED/GREEN wire. It is activated on protection intervention. It is silenced by pressing the button .

INSTRUMENT

The control unit comprises five instruments selectable in sequence by pressing the button .

HOUR-METER	-Total hours of operation (with the engine running the signal pulsates to indicate the correct functioning of the HOUR-METER.	}	ON REQUEST
PARTIAL HOURS	- The hours are reset at the next start-up		
OIL PRESSURE GAUGE	- Engine Oil pressure.		
THERMOMETER	- Engine oil and water temperature		
PUMP WATER PRESSURE GAUGE	- Engine water pressure.		
TACHOMETER	- Speed of motor pump		
FUEL LEVEL INDICATOR	- Fuel level percentage		
VOLTMETER	- Battery voltage		







Lit up when the control unit is **ON**, they turn off with the engine running and normal oil pressure and battery recharging system.

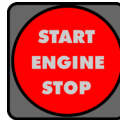

USER PROGRAMMING AND TACHOMETER SETTING

ACCESS TO PROGRAMMING MODE



- Switch on the control unit by pressing the START button .
- Press the   buttons at the same time until the message disappears "USER PROGRAMMING".

USER PROGRAMMING

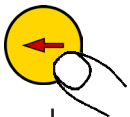

PRESS TO DISPLAY THE
REQUIRED PROGRAMMING

LANGUAGE CHOICE. The language set up in the factory is ITALIAN; the languages that can be selected are: ENGLISH - FRENCH - GERMAN - SPANISH and PORTUGUESE.

LANGUAGE CHOICE
ENGLISH

LANGUAGE SELECTION
ENGLISH

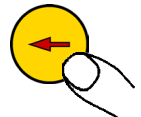

Press and wait for
PROGRAMMED to be
written.

LANGUAGE
CHOICE

Press to select language.



TACHOMETER
SETTING

Start the engine by pressing the START/STOP button and bring the engine to idle at constant known speed for example via a portable tachometer. After calibrating the tachometer, stop the engine by pressing the START/STOP button.

Displayed on the display Example

700 RPM

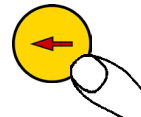

1500 RPM



Press until you get the right
indication on the display

Press and wait for
PROGRAMMED to be
written.



To exit the settings, press the   buttons at the same time or don't press any button for 30 seconds.

WIRING DIAGRAM

COOLANT LEVEL PROBE

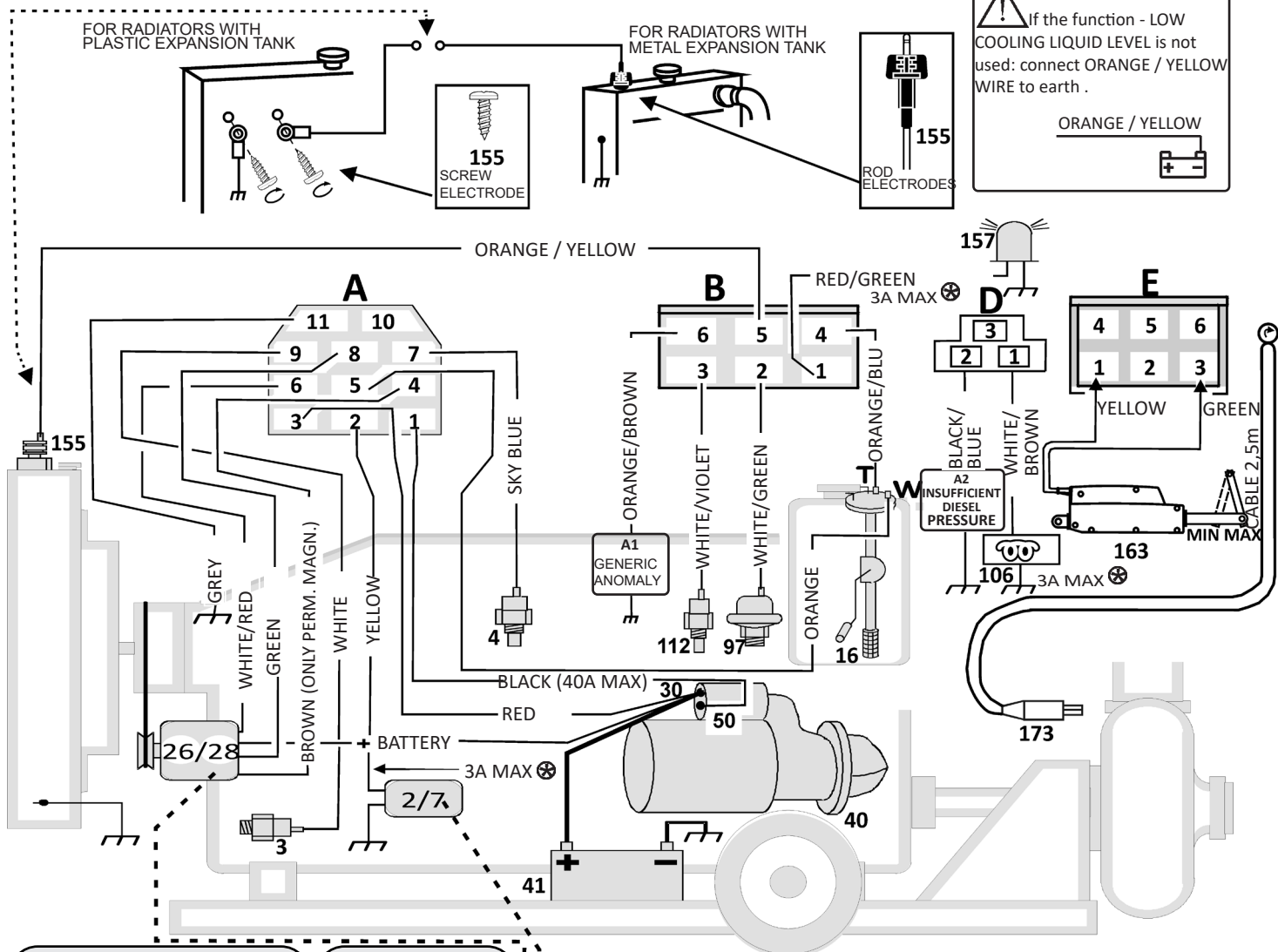

⚠ If the function - LOW COOLING LIQUID LEVEL is not used: connect ORANGE / YELLOW WIRE to earth.

ORANGE / YELLOW

FUSES SUBSTITUTION
THE FUSES ARE INSIDE THE CONTROL UNIT. TO ACCESS THE INSIDE REMOVE THE FRONT PANEL BY UNSCREWING THE FOUR SCREWS. REPLACE WITH A FUSE OF THE SAME VALUE.

⚠ **ATTENTION**
FOR LOADS WITH HIGHER ABSORPTION 3A IT IS ESSENTIAL TO PUT A RELAY

ELIMINATE THE BRIDGE WHEN CONNECTING THE EMERGENCY BUTTON

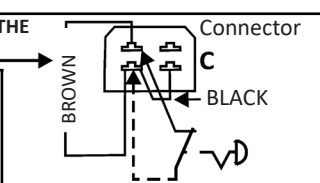

EMERGENCY STOP
This can be obtained with a latching button on releasing the emergency button, starting or motion of the engine is stopped.
Release the stop button and press the START/STOP button.

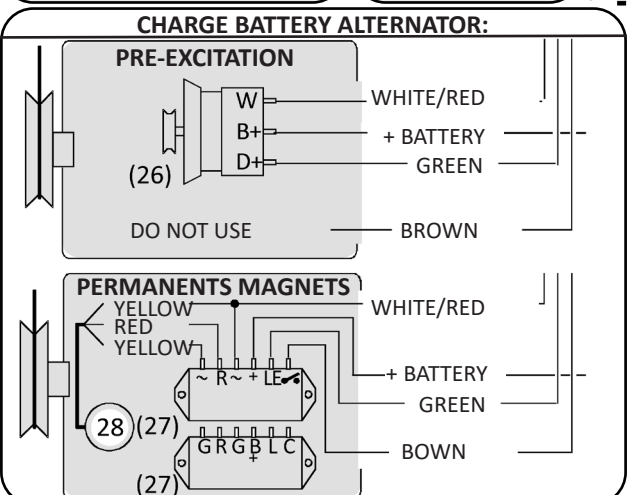

- ACCESSORIES ON REQUEST**
- (2/7) ELECTROMAGNET OR ELECTROVALVE ⚠
 - (4) THERMOSTATIC SWITCH
 - (15) WATER PUMP PRESSURE SWITCH
 - (16) FUEL FLOAT
 - (97) OIL PRESSURE TRANSMITTER
 - (112) TEMPERATURE TRANSMITTER
 - (155) RADIATOR LIQUID LEVEL PROBE
 - (163) SPEED VARIATOR
 - (173) PUMP WATER PRESSURE TRANSMITTER (SUPPLIED)

- MOUNTED ON ENGINE**
- (3) OIL PRESSURE SWITCH
 - (26/28) PERMANENT MAGNETS CHARGE ALTERNATOR OR PRE-EXCITATION CHARGE ALTERNATOR
 - (27) ALTERNATOR REGULATOR
 - (40) STARTING MOTOR
 - (41) BATTERY
 - (106) GLOW PLUGS
 - (157) VISUAL INDICATOR (GENERAL ALARM) ⚠

INSULATE POSSIBLE CABLES NOT CONNECTED

EXCITED IN STOP MODE
The control panel is arranged to command stop with ELECTRO-MAGNET

ELECTROMAGNET :
activates the engine stop lever. Inserire un relè sul filo giallo.

EXCITED IN DRIVE
SOLENOID : to close the fuel.

NOTICES

Only for starting and surveillance of the diesel motor pump and stops it if there are anomalies in the parts controlled by probes. It has been designed to be installed also on the machine.



Warning:
adhere closely to the following advice

- Install in such a way that there is always adequate heat disposal.
- Always follow the Wiring Diagram on page 6 when making connections.
- All technical interventions must be performed with the engine stationary and terminal 50 of the starter motor disconnected.
- Check that the line loading and the consumption of the connected equipment are compatible with the described technical characteristics described on page 2.
- Always install under other equipment which produces or spreads heat.
- Never use a battery charger for the emergency start-up, the control unit could be damaged.
- In order to safeguard people and equipment, before connecting an external battery charger, disconnect the electrical system terminals from the battery poles.
- Never disconnect the battery terminals with the motor pump running.

THIS CONTROL UNIT IS NOT SUITABLE FOR OPERATING IN THE FOLLOWING CONDITIONS:

- Where the environmental temperature is outside the limits indicated in the Technical Data on page 2.
- Where there are high levels or heat from radiation caused by the sun, ovens or the like.
- Where there is the risk of fire or explosions.
- Where the control unit can receive strong vibrations or knocks.

ELECTROMAGNETIC COMPATIBILITY

This control unit functions correctly only if inserted in plants which conform with the CE marking standards; it meets the exemption requirements of the standard EN61326-1 but it cannot be excluded that malfunctions could occur in extreme cases due to particular situations.

The installer has the task of checking that the disturbance levels are within the requirements of the standards.

CONDUCTION AND MAINTENANCE

The following maintenance operations should be performed every week:

- check that the indicators function;
- check the batteries;
- check that the conductors are tight, check the condition of the terminals.

UNLESS WE MAKE A WRITTEN DECLARATION STATING THE CONTRARY, THIS CONTROL UNIT IS NOT SUITABLE FOR USE AS A CRITICAL COMPONENT IN EQUIPMENT OR PLANTS RESPONSIBLE FOR KEEPING PERSONS OR OTHER LIVING BEINGS ALIVE.

YOUR ELECTRICAL TECHNICIAN CAN ASK US ANYTHING ABOUT THIS CONTROL UNIT
BY TELEPHONING ONE OF OUR TECHNICIANS

ORDERING DATA

- Type CEM-390

code 00210735

ACCESSORIES KIT

- Pre-wired female connector type CEM-390
- KIT rods CEP/CEM
- Pump water pressure transmitter TYPE TPA-200
- Nipple F1/4" GAS -M3/8"GAS

code 70804418

code 40804362

code 70500255

code 70190241

ACCESSORIES ON REQUEST

RADIATOR COOLANT LEVEL PROBE

ROD ELECTRODE (complete with: rivet connection, bolt, nut, washer, seal and female connector)

type AST-015/00

code 40241012



SCREW ELECTRODE (complete with lugs)

type E-25

code 40190115

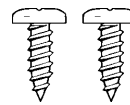

SPEED VARIATOR

type VAR-140 12V

code 00571543



SUPPORT FOR INSTALLATION ON BASE

type CRU-003

code 40493384

