



ENAPART



93 S Railroad Avenue Unit C
Bergenfield NJ 07621 USA
www.enapart.com
sales@enapart.com



Via del Canneto 35,
Borgosatollo, Brescia - Italia
www.enapart.it
vendite@enapart.it



Barbaros Mah. Ihlamur Bul. Aĝaoĝlu
My Newwork No:3/15 Ataşehir / İstanbul
www.enapart.net
satis@enapart.net



PRIVADA 10 B SUR #3908 COL.
ANZUREZ, C.P. 72530, PUEBLA, PUE
www.enapart.com.mx
sales@enapart.com.mx



Friedrich-Ebert-Anlage 36, 60325
Frankfurt am Main, Germany
www.enapart.de
anfrage@enapart.de



4 boulevard Carnot, 95400
villiers-le-bel, Paris, France
www.enapart.fr
sales@enapart.fr



65049, ОДЕСА, ВУЛИЦЯ ІВАНА
ФРАНКА, БУДИНОК 55, ПОВЕРХ 3
www.enapart.com.ua
sales@enapart.com.ua



MUNICIPIUL BUCUREȘTI, SECTOR 3,
B-DUL BASARABIA, NR.250, CORP P+5
www.enapart.ro
sales@enapart.ro



〒584-0023 大阪府富田林市若松町
東2丁目2番16号
www.enapart.co.jp
sales@enapart.co.jp



PLAZA NUESTRA SEÑORA DE LAS
NIEVES 12 ,LOCAL ,50012,ZARAGOZA
www.enapart.es
ventas@enapart.es



Складова база „Онгъл“, Склад А2, п.к.
4006, гр. Пловдив, България
www.enapart.bg
sales@enapart.bg



3 Austin Mews, High Street, Hemel
Hempstead, HP1 3AF , United Kingdom
www.enapart.co.uk
sales@enapart.co.uk

ASM 124S, 134S: Damper actuator with SAUTER Universal Technology (SUT)

Improving energy efficiency

Torque-dependent cut-off facility for efficient usage of energy

Features

- For controllers with switching (2- and 3-point) or continuous output (0...10 V)
- For operating air dampers, shut-off dampers, butterfly valves and multi-leaf dampers
- Self-centring spindle adapter
- Gear unit can be disengaged to position the damper and for manual adjustment
- Stepping motor with electronic activation and cut-out
- Maintenance-free
- Intelligent adaptation of angle of rotation, incl. feedback adjustment
- Direction of rotation changed by transposing the connections
- Suitable for all fitting positions
- Version with halogen-free cable on demand



ASM1*4SF132

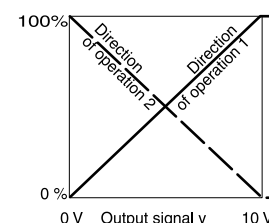

Technical data

Power supply		
	Power supply 24 V~	±20%, 50...60 Hz
	Power supply 24 V ¹⁾	±20%
Parameters		
	Angle of rotation	Max. 95°
	Admissible damper shaft (hardness)	Max. 300 HV
	Operating noise	< 30 dB(A)
	Response time	200 ms
Positioner		
	Control signal	0...10 V, R _i > 100 kΩ
	Positional feedback signal	0...10 V; load > 10 kΩ
	Starting point U ₀	0 or 10 V
	Control span ΔU	10 V
	Switching range X _{sh}	200 mV
Ambient conditions		
	Admissible ambient temperature	-20...55 °C
	Admissible ambient humidity	< 95% rh, no condensation
Construction		
	Weight	1.6 kg
	Housing	Lower section black, upper section yellow
	Housing material	Fire-retardant plastic
	Power cable	1.2 m long, 2 × 0.75 mm ²
Standards and directives		
	Type of protection	IP 40 (EN 60529), IP 43 (EN 60529), IP 54 (EN 60529)
	Protection class	III (IEC 60730)
	EMC directive 2004/108/EC	EN 61000-6-1, EN 61000-6-2 EN 61000-6-3, EN 61000-6-4
	Mode of operation	Type 1C (EN 60730); type 1 AB (EN 60730)
	Software	A (EN 60730)

¹⁾ 24 V= only for control signals 0...10 V



Overview of types

Type	Torque	Holding torque	Running time for 90°	Power consumption	Admissible damper shaft
ASM124SF132	15 Nm	15 Nm	60, 120 s	2.4 W, 4.4 VA	Ø 10...20 mm, □ 10...16 mm
ASM134SF132	30 Nm	30 Nm	120, 240 s	2.4 W, 4.3 VA	Ø 12...20 mm, □ 10...16 mm

Power consumption when idle:

 ASM124SF132: 0.25 W, 0.46 VA

 ASM134SF132: 0.26 W, 0.48 VA

Accessories

Type	Description
0313529001	Split-range unit for adjusting sequences, fitted in separate junction box
0361977001	Assembly materials for M3R/M4R, MH32F/MH42F with ASM 124
0370059000	Clamping lever for shaft, Ø 8...18 mm
0370990001	Auxiliary change-over contacts, single
0370990002	Auxiliary change-over contacts, double
0370992001	Potentiometer, 2000 Ω, 1 W
0370992002	Potentiometer, 130 Ω, 1 W
0372200001	Fitting bracket
0372201001	Spindle extension with coupling
0372202001	Lever, fitting strip
0372203001	Driver axle for auxiliary contacts
0372204001	Spindle for clamping lever 0370059

 Auxiliary change-over contacts: Infinitely variable 0...90°, admissible load 5(2) A, 24...230 V

Description of operation

The concept of stepping motor and electronics enables electrical parallel operation of multiple air dampers with different torques when actuators of the same SUT type are used. Depending on the type of connection (see connection diagram), the actuator can be used as a continuous 0...10 V, 2-point ON/OFF or 3-point ON/OFF actuator with an intermediate position.

The running time of the actuator can be set with switches S1 and S2 according to requirements. The manual adjustment is performed by turning the spindle adaptor after releasing the gear unit (button on housing cover).

Intended use

This product is only suitable for the purpose intended by the manufacturer, as described in the "Description of operation" section.

All related product documents must also be adhered to. Changing or converting the product is not admissible.

Additional technical data

The upper section of the housing with the cover, manual adjustment knob and cover knob contains the stepping motor and the SUT electronics. The lower section of the housing contains the maintenance-free gear unit and the spindle adaptor.

Auxiliary change-over contacts

Switch rating max. 250 V~, current min. 20 mA at 20 V

Switch rating max. 4...30 V=, current min. 1...100 mA

Connection as 2-point control unit

This OPEN/CLOSE activation can be performed via 2 wires. The actuator is connected to the voltage via the blue and brown cables. The damper actuator is moved to the end position by connecting the voltage to the black cable (2b) (clockwise direction to 100% angle of rotation). After the voltage is switched off, the actuator moves to the opposite end position.

The unused red and grey wires must not be connected or come into contact with other cables. We recommend that you insulate these.

Connection as 3-point control unit

When voltage is applied to the cable (2a or 2b), the damper actuator can be moved to any desired position. Direction of rotation (viewing the spindle adaptor from the actuator):

- The spindle adaptor turns in the clockwise direction, with the voltage on the black cable (2b).
- The spindle adaptor turns in the anti-clockwise direction, with the voltage on the brown cable (2a).

In the end positions (limit stop of damper, limit stop due to angle-of-rotation limit, max. angle of rotation of 92° reached) or in the case of an overload, the electronic motor cut-off is activated (no limit switches). Direction of rotation changed by transposing the connections.

The unused red and grey wires must not be connected or come into contact with other cables. We recommend that you insulate these.

Connection for control voltage 0...10 V

The built-in positioner controls the actuator depending on controller's output signal y

Direction of rotation (viewing the spindle adaptor from the actuator):

Direction of operation 1 (mains power supply on brown cable, internal connection 2a):

When the positioning signal is increasing, the spindle adaptor turns in the clockwise direction

The starting point and the control span are fixed.

Depending on the direction of operation, only the brown cable or the black cable may be connected.

The other cable must be insulated.

When the voltage is connected, the stepping motor moves to the two end stops one after the other, and determines its effective angle of rotation (always with a running time of 60 s). Thanks to the electronics, no steps can be lost, and the actuator does not require periodic re-adjustment. After a manual adjustment or a power failure of more than at least 5 min, the actuator automatically readjusts itself.

When the angle of rotation is changed, the manual adjuster must be used to trigger a new adjustment so that the actuator, the control voltage 0...10 V and the feedback signal adjust to the new angle of rotation. Switch S3 can be used to switch off the initialisation. The actuator then always works with the last limit stops saved. If it detects a new limit stop, this is saved and the feedback signal is adjusted accordingly. In the case of a power failure longer than at least 5 min, the positioning motor works without initialisation from the current position. The current setpoint is output as a feedback signal until a limit stop is reached and the current position can be calculated and output. When control signal 0...10 V is interrupted and direction of operation 1 is connected, the damper is closed completely (0% position).

Coding switch

ASM 124S Running time	ASM 134S Running time	S1	S2	S3
120 s	240 s	OFF	ON	–
120 s	120 s	ON	ON	–
60 s	120 s	ON	OFF	–
60 s	240 s	OFF	OFF	–
Initialisation on		–	–	ON
Initialisation off		–	–	OFF
Factory setting position		ON	ON	ON

Split-range unit, accessory 361529 001

Starting point U_0 and control span ΔU can be set with the potentiometer. In this way, several control units can be operated in sequence or cascade by the control signal of the controller. The input signal (partial range) is amplified into an output signal of 0...10V. This accessory cannot be built into the actuator but must be externally housed in an electrical junction box.

Engineering and fitting notes

The actuator can be fitted in any position and can be plugged directly onto the damper spindle and fixed by means of the self-centring clamping lever. To conserve the damper bearings, the damper spindle is turned by the self-centring spindle adaptor. Note! The housing must not be opened. The coding switches are accessible via an opening with a black cover in the housing lid.



Note

The housing must not be opened. The coding switches are accessible via an opening with a black cover in the housing lid.

The maximum accessory equipment for an actuator is: Accessory: 1 single change-over auxiliary contact or 1 double auxiliary contact or 1 potentiometer. With the ASM 134, such accessories cannot be mounted if the length of the damper spindle < 52 mm. The angle of rotation can be limited to between 0° and 90° in 5° stages. The limitation is defined by means of a setting disc (under the coupling piece). With the ASM 124, the coupling piece is suitable for Ø 10...20 mm and 10...16 mm damper spindles. With the ASM 134, the coupling piece is suitable for Ø 12...20 mm and 10...16 mm damper spindles.

Outdoor installation

We recommend protecting the devices from the weather if they are installed outside buildings.

Disposal

When disposing of the product, observe the currently applicable local laws.

More information on materials can be found in the Declaration on materials and the environment for this product.

Connection diagram

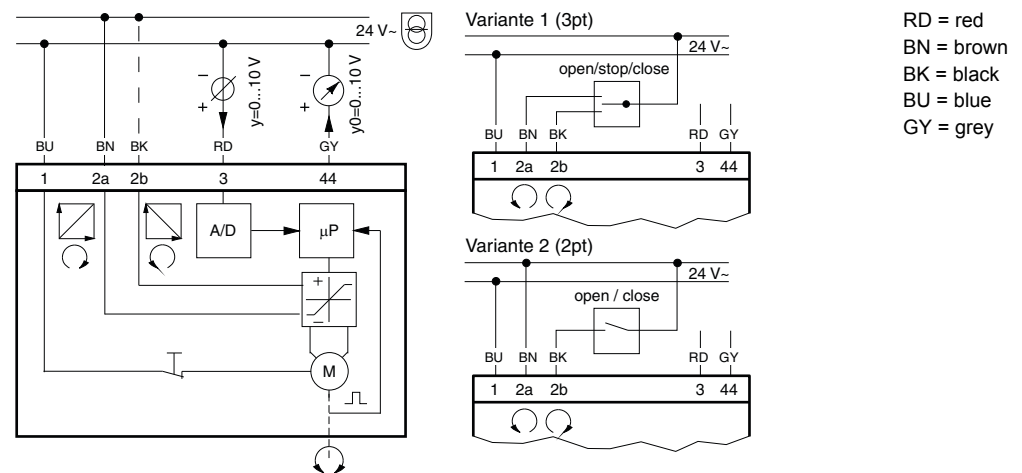

Direction of operation 1:
2a closed, 2b open
Direction of operation 2:
2b closed, 2a open

Accessories

<p>370990/001</p>	<p>370990/002</p>	<p>370992/...</p>
<p>0313529</p> <p>MM 01/02/LS 03</p> <p>AVM ... S AVF ... S ASF ... S AXM ... S ASM ... S AKM ... S</p>		

Dimension drawing

ASM 124: Ø 10...20 mm
□ 10...16 mm

ASM 134: Ø 12...20 mm
□ 10...16 mm

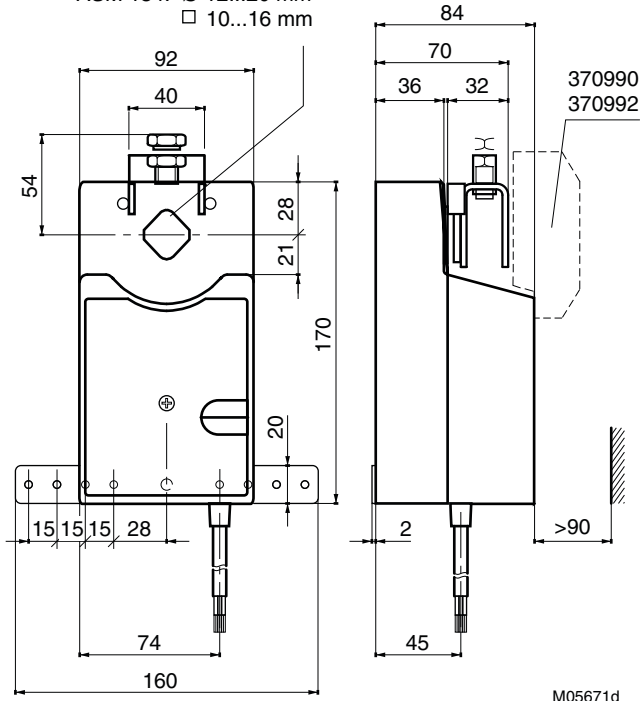

Accessories

